

2.5 SET

NFPA 1851 EXTRACTOR PACKAGE

FITS THROUGH A 36" DOOR



PRE-WIRED DUAL CHEMICAL PUMP AND CHEMICALS

Includes 5 Gallons of Safety Suds Bunker Gear Detergent and BacStop EPA rated fabric sanitizer.

PERFECTLY TUNED EXTRACT PERFORMANCE

with optimally programmed 100G performance to achieve max extraction and to prevent unbalanced loads.

QUALITY DESIGNED EXTRACTORS

are manufactured using the world's most advanced robotic assembly line, delivering consistent high quality.



EASY INSTALLATION

Soft-Mount with no concrete pad required - just drop in place.

EASY TO USE CONTROLS with an intuitive design and multi-lingual support.

NFPA 1851 ISP OPTIMIZED PROGRAMMING

- 7 Fire Department programs
- Outer Shells
- Thermal Liners
- Heavy Soil
- Wildland / Tech Rescue
- Gloves & Hoods
- Shop Towels

BUILT FOR A LONG LIFE

10 Year Limited Warranty. including a plasma welded stainless-steel drum and tub, high quality bearings, UL certified critical components, a durable motor and the CSA mark of quality.

BEFORE WE SHIP

we perform a double quality check to ensure that each washer is perfect right out of the box.

info@toxicsuppression.com



FREE SHIPPING!
10 YEAR WARRANTY

SPECIFICATIONS

Capacity - lb	25
Cylinder Volume - ft ³	3.2
Extraction - G-force	300
Noise Level at Extraction - dBA	<62
Noise Level at Wash ₁ - dBA	<52

ELECTRICAL CONNECTIONS

Main Voltage - v/Hz/PH	208-240/60/1-Ph
Total Power - kW	1.2
Circuit Breaker - amps	15

WATER INFORMATION

Water Valves	$\frac{3}{4}$ " Garden Hose (2 inlets) ²
Recommended Water Pressure - kPA, (PSI)	200-600, (30-90)
Modified Energy Factor - MEF	2.5
Water Factor - IWF	3.7

DYNAMIC FLOOR LOAD

Floor Load at Maximum Extraction - kn, (lb)	0.46 ± 0.2, (103 ± 45)
Dynamic Force Frequency - Hz	7.5

INLET WATER TEMPERATURE (MAX)

Liquid Chemical Supplies - in.	$\frac{3}{4}$ x 1 $\frac{7}{8}$ x 1 $\frac{3}{8}$ x 5
--------------------------------	---

DIMENSIONS

Width – in.	27
Depth ₃ – in.	32 $\frac{7}{16}$
Height ₄ – in.	47 $\frac{1}{16}$
Height to Bottom of Door ₄ – in.	14 $\frac{25}{32}$
Door Opening Diameter – in.	20 $\frac{43}{64}$
Drain Outlet Diameter – in.	2 or 3
Height to Centerline of Drain ₄ – in.	4 $\frac{1}{8}$
Shipping Width - in.	28.98
Shipping Depth - in.	35.83
Shipping Height - in.	51.77
Shipping Weight - lb.	463

¹ Sound power levels measured according to ISO 60704.

² Water supplies must have individual shut-off valves. Washing machine water connections are Garden Hose thread (GHT). Use quality, pressure-rated, hoses to prevent leaks. Hoses are available from Hero Laundry.

³ Depth excluding door handle and drain-outlet fitting. Handle adds 37.5mm (1 1/2") to overall depth. Drain outlet adds 20mm (3/4") to overall depth.

⁴ Height excluding adjustable height of the leveling legs. Add 44mm (1 3/4") height of machine when leveling legs are installed and fully extended.

Certified in accordance with cCSAus standards.

The manufacturer reserves the right to make changes to design, without notice.

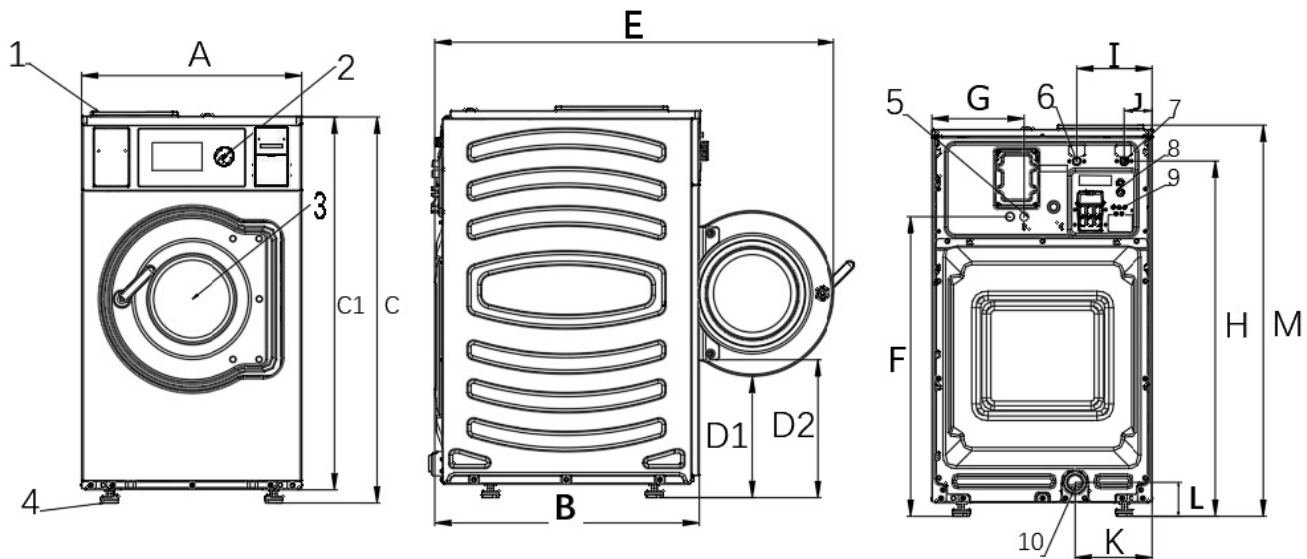

1	Automatic laundry-chemical dispenser
2	Operating panel
3	Door opening, ϕ 310 mm / 12 inch
4	Leveling legs
5	Electrical connection
6	Cold water inlet
7	Hot water inlet
8	Re-used water
9	External chemical pump tube connection
10	Drain outlet

A	686 mm (27 in)
B	824 mm (32 1/2 in)
C	1195.5 mm (47 in)
C	1154.5 mm (45 1/2 in)
D	375.5 mm (14 3/4 in)
D	455 mm (17 7/8 in)
E	1243.5 mm (49 in)
F	926 mm (36 1/2 in)

G	286 mm (11 1/4 in)
H	1097.5 mm (43 1/4 in)
I	237.5 mm (9 1/3 in)
J	91 mm (3 1/2 in)
K	242.5 mm (9 1/2 in)
L	105 mm (4 1/8 in)
M	1209 mm (47 1/2 in)